



Project _____

Model # _____ Quantity _____



Countertop Chafing Dish *with heating element*

Model #	Voltage	Peak Power	Plug Type
2585-6A	110-120	450 W	NEMA 5-15P

Description:

Spring USA's Countertop Chafing Dish with heating element is a full-size, mirror-polished chafer designed for serving prepared food. Each chafer comes with (2) half-size inserts and an electric heating element to keep heated food at the proper temperature.

Construction & Performance

Features:

- 18/8 polished stainless steel
- Non-slamming, resistance axle system
- Removable, roll-top cover
- Water channel
- Scratch/slip resistant feet
- Easy-read water fill line printed on inside of chafer
- Oven and dishwasher safe inserts

- Includes (2) half-size, stainless steel, inserts and (1) 450-watt electric heating element.



Half-size Insert
(Item #522-66/12C)



Heating Element
(Item #9517)

Standard Warranty:

- 10 year warranty for manufacturer defects on welds & castings

Agency Listings:

- ETL (chafing dish)
- NSF 2 (chafing dish)
- CE (heating element)



Sept 2018

Countertop Chafing Dish

Available Accessories:

- Accepts all 521 and 522 hotel pan inserts



Electric Requirements:

Below electrical requirements are based on the included heating element.

Model #	Voltage	Phase	Hertz	Watts	Amps	Plug
2585-6A	110-120	1	60	450	3.8	NEMA 5-15P

Key Dimensions:

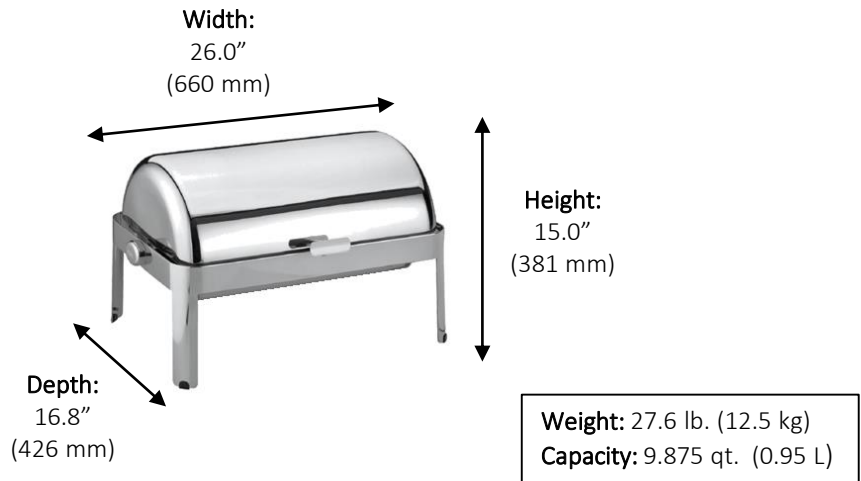

Shipping Dimensions:

Single Unit Shipping Carton				
Model #	Length	Width	Height	Weight
2585-6A	28.1" (715 mm)	21.1" (535 mm)	13.8" (350 mm)	35.8 lb. (16 kg)

Notes & Conditions:

1. The Countertop Chafing Dish with heating element only maintains temperature – it does not cook or continue to cook food.