



Project \_\_\_\_\_  
Item # \_\_\_\_\_ Quantity \_\_\_\_\_



## Milk Dispenser

Model #	Capacity
2528-6/5	5.3 qt. / 5 L

### Description:

Spring USA's Milk Dispenser is an exclusive design featuring unique details. With a separate ice core, the dispenser can keep a beverage cool without diluting it. Each dispenser is of superior quality, high-polished, stainless steel and includes a solid, stainless steel faucet.

### Construction & Performance Features:

- 18/10 mirror-polished, stainless steel
- Stainless steel ice tube
- Oblong base with drip tray
- Solid cast, stainless steel faucet
- 5.3 qt. / 5 L capacity

### Available Accessories/Alternate Configurations:

- Beverage dispenser [See Spring USA Catalog]
- Coffee urn [See Spring USA Catalog]
- Separate milk can [Item # 528-66/5]
- Replacement drain plate [Item #525-5/7]
- Replacement dish [Item #526-5/7]
- Replacement faucet [Item #528-05S]
- Replacement ice tube [Item #528-IT]

### Agency Listings:

- NSF



### Standard Warranty:

- One year, parts & labor

### Key Dimensions:

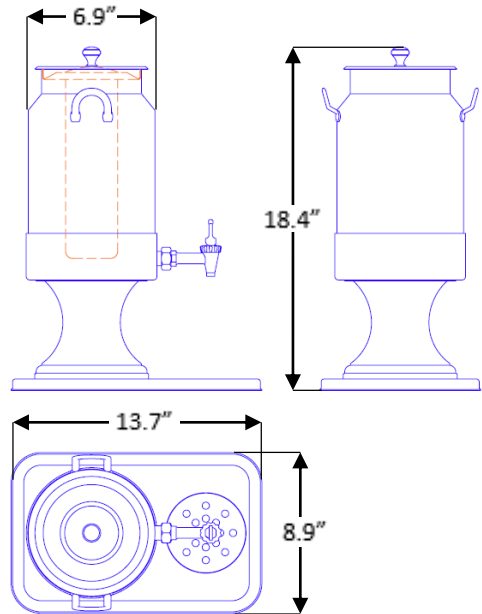

Net Weight: 16 lb.