



## Built-In Induction Range

(Model Shown: SM-181R)

Model #	Voltage	Peak Power	Plug Type
SM-181R (US)	110-120	1800 W	NEMA 5-15P
SM-261R (US)	208-240	2600 W	NEMA 6-20P
SM-263R (Int'l)	220-240	2600 W	CEE-7/7 16A Schuko
SM-263RU (UK)	220-240	2600 W	BS 1363 (13A) U.K.

### Description:

Spring USA's Built-In Induction Range is a heating unit for product cooking or holding. The range is flush mountable and features an installation-ready modular flanged base and separate control panel. Each range includes our exclusive SmartScan® technology with over/under voltage protection, pan size and pan type recognition, and large LED power/temp display.

### Standard Warranty:

Spring USA Induction Ranges offer a one-year, overnight exchange warranty (continental US only), from the date of invoice, against manufacturers defects. See SpringUSA.com for more details.

### Agency Listings:

- ETL
- UL STD 197
- FCC
- CETL
- ETL-Sanitation to NSF-4





Project \_\_\_\_\_

Item # \_\_\_\_\_ Quantity \_\_\_\_\_

Model # \_\_\_\_\_

### Built-In Induction Range

#### Construction & Performance Features:

- Sealed induction base with flanged cooking surface for easy drop-in mounting
- Separate control panel with 43" (1.1 m) cable for easy mounting
- Mounting frame bracket
- Rugged, 5 mm thick, easy to clean, tempered glass top
- 100% silicone rubber protective top seal
- 7' power cord with plug
- Simple, solid state controls
- Power ON/OFF heavy duty knob
- Power ON/Pan-Present indicator lights
- 'Cook' or 'Temp' mode
- 'Cook'/'Temp' mode touch pad control
- 'Cook'/'Temp' mode indicator lights
- Simple, knob-set thermostat control
- Lighted temperature indicator
- Power level 1-20 in 'Cook' mode
- Temperature range 110°F-400°F (43°C-204°C) in 'Temp' mode

#### Available Accessories/Alternate Configurations:

- Universal flush mounting flange/adapter plate [PN: AP1826]
- Induction-ready Cookware and Serving Vessels [Spring USA Catalog]
- AF-350 Under-Counter Air Filter System
- Built-In, High Power Induction Ranges
- Countertop, Portable Induction Ranges
- Custom Tabletop Induction featuring SmartStone®
- Mobile & Custom Configurations [Contact Spring USA]

#### Electric Requirements:

Model #	Voltage	Phase	Hertz	Watts	Amps	Plug
SM-181R (US)	110-120	1	60	1800	15.0	NEMA 5-15P
SM-261R (US)	208-240	1	60	2600	10.8	NEMA 6-20P
SM-263R (Int'l)	220-240	1	50-60	2600	10.8	CEE-7/7 16A Schuko
SM-263RU (UK)	220-240	1	50-60	2600	10.8	BS 1363 (13A) U.K.

## Built-In Induction Range

### Key Dimensions:

**SIDE VIEW**

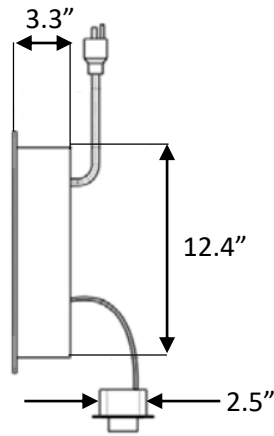

**TOP VIEW**

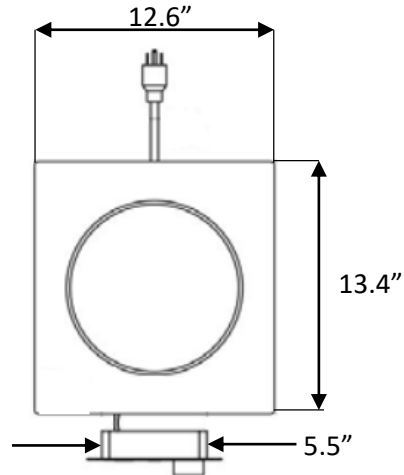

Range cutout: 13.5" L x 12.7" W  
(342 mm L x 322 mm W)

Control box cutout: 5.7" L x 2.7" W  
(146 mm L x 69 mm W)

**FRONT VIEW**

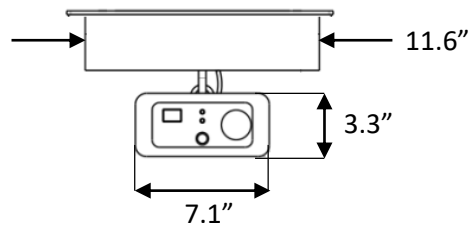

Model #	Width	Depth	Height	Weight
SM-181R (US)	12.6"	13.4"	3.3"	10.8 lb.
SM-261R (US)	12.6"	13.4"	3.3"	11.7 lb.
SM-263R (Int'l)	320 mm	340 mm	84 mm	5.4 kg
SM-263RU (UK)	320 mm	340 mm	84 mm	5.4 kg



Project \_\_\_\_\_

Item # \_\_\_\_\_ Quantity \_\_\_\_\_

Model # \_\_\_\_\_

## Built-In Induction Range

**Shipping Dimensions:**

Single Unit Shipping Carton				
Model #	Length	Width	Height	Weight
SM-181R (US)	18.0"	15.5"	4.5"	13.0 lb.
SM-261R (US)	19.5"	16.0"	5.5"	13.0 lb.
SM-263R (Int'l)	495 mm	406 mm	140 mm	5.8 kg
SM-263RU (UK)	495 mm	406 mm	140 mm	5.8 kg

**Notes & Conditions:**

1. This induction range must be surface mounted (by others) in a heat resistant countertop (2" thick maximum) or base cabinet with the control module mounted on the front of that enclosure [see cutout dimensions above].
2. For optimum performance, allow 4" clearance from front and sides; 7" below unit for good air circulation. **Cabinet ventilation must be provided.** The inside temperature of the cabinet must not exceed 90°F/32°C.
3. Actual range temperature may vary due to a number of variables, such as ambient temperature in the immediate surrounding area, content and volume of food being heated or cooked, and whether or not you are using a cover on the serving vessel.
4. This induction range requires use of ferrous metal, induction-ready cookware.
5. Spring USA Induction Servers and Induction Warmers/Ranges are designed to work together as a system. Optimal performance is achieved by using Spring USA components in conjunction with each other. As the first to offer such induction systems, Spring USA cannot warranty the performance of facsimile products offered by other companies.

Aug 2019